

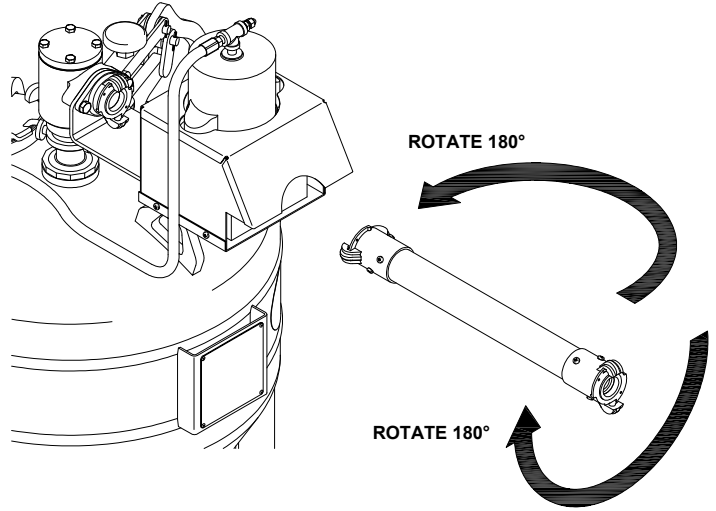

# Pinch Hose Replacement Guide

Every 10 hours of blasting, we recommend rotating the pinch hose. At this time a visual inspection should be performed to insure integrity. Look at and feel it carefully for signs of wear, softness, or bulges. You want to replace your pinch hose **before** it fails. After rotating it 4 times (which should be after 40 hours of use) we recommend replacement. The hose can be positioned four ways. You can rotate the entire hose, reversing the ends, and you can just flip the hose over. Try to flip it into all four positions, not letting it repeat positions during it's 40 hour life. In other words, after 10 hours, turn the hose over. 10 hours later, rotate the entire hose, reversing the ends. 10 Hours later, turn it over again. 10 hours after that, you should take it out and replace it. The pinch hose is inexpensive and 4 are provided. The instructions below will explain how to swap the couplings onto the new pinch hose.



## To remove brass coupling from old pinch hose:

Lock hose in vice and remove screws using a phillips head screwdriver or drill.

Unscrew brass coupling from hose turning counter-clockwise. You may need a bar or rod to do this.

## To attach brass coupling to new pinch hose:

Lock hose in vice, making sure an adequate length of hose is left protruding.

Wrap the end of the hose in several layers of friction tape, a little beyond the point the brass will cover.

Place coupling over friction tape and hose, screwing clockwise until hose end pushes against inside brass ridge of coupling. You may need a bar or rod to get it tight.

Wrap screws with Teflon tape and screw into designated holes until tight.

**Please follow these instructions carefully. MMLJ Inc. will not be held responsible for injury due to pinch hose failure. If you need to order new pinch hoses, or if you have any questions please call us at 800-727-5707.**

**800-727-5707**

**[www.DustlessBlasting.com](http://www.DustlessBlasting.com)**